

**DANGER / DANGER / PELIGRO /  
GEFAHR / PERICOLO / ОПАСНО**

**HAZARD OF ELECTRIC SHOCK, EXPLOSION,  
OR ARC FLASH**

Disconnect all power before servicing equipment.  
Failure to follow these instructions will result in  
death or serious injury.

**RISQUE D'ÉLECTROCUTION, D'EXPLOSION  
OU D'ARC ELECTRIQUE**

Coupez toutes les alimentations avant de travailler  
sur cet appareil.  
Le non-respect de ces instructions provoquera  
la mort ou des blessures graves.

**PELIGRO DE DESCARGA ELÉCTRICA, EXPLOSIÓN  
O ARCO ELECTRICO**

Desconecte todas las alimentaciones antes  
de manipular el producto.  
Si no se siguen estas instrucciones provocará  
lesiones graves o incluso la muerte.

**GEFAHR VON ELEKTRISCHEM SCHLAG,  
EXPLOSION ODER LICHTBOGEN**

Vor dem Arbeiten am Gerät alle  
Spannungsversorgungen abschalten.  
Die Nichtbeachtung dieser Anweisungen führt zu  
Tod oder schwerer Körperverletzung.

**RISCHIO DI SCARICA ELETTRICA , ESPLOSIONE  
O ARCO ELETTRICO**

Scollegare l'apparecchio da tutti i circuiti di  
alimentazione prima di qualsiasi intervento.  
Il mancato rispetto di queste istruzioni provocherà  
morte o gravi infortuni.

Опасность поражением электрическим током,  
опасность взрыва или вспышки дуги.  
Перед обслуживанием или ремонтом  
убедитесь, что питание отключено.  
Несоблюдение этих инструкций приведет  
к смерти или серьезной травме.

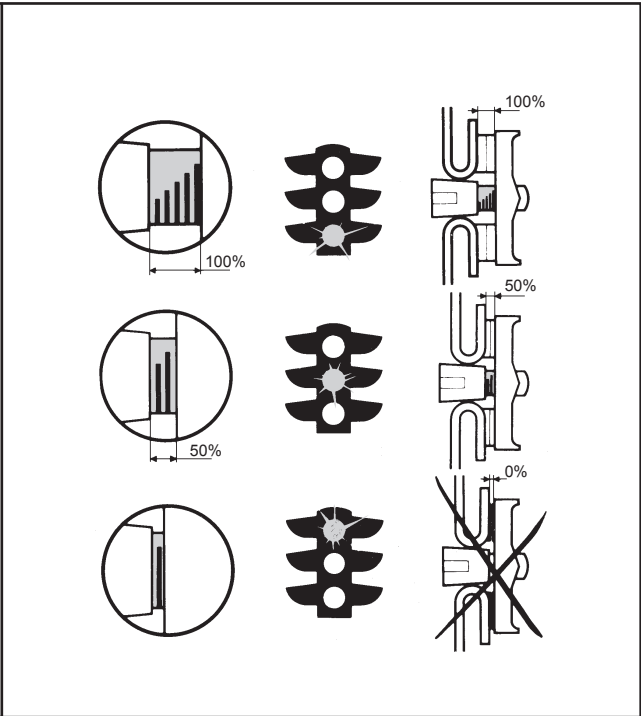
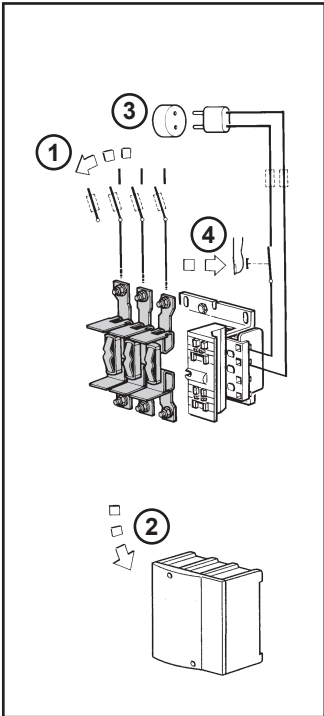

**LA5-FF. /FG. /FH.**

**LA5-F400**

**LA5-F500 ... 800**

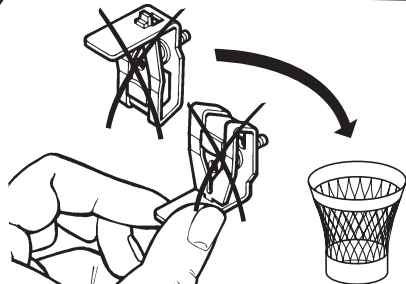
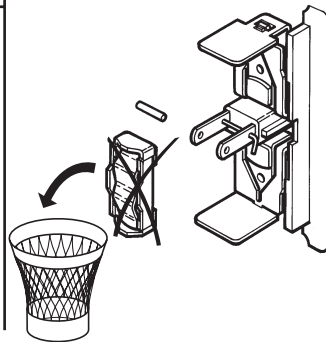
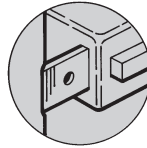
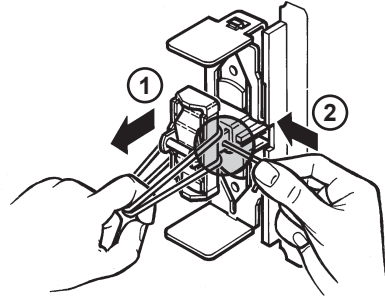
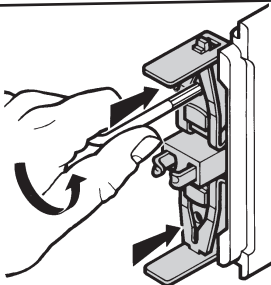
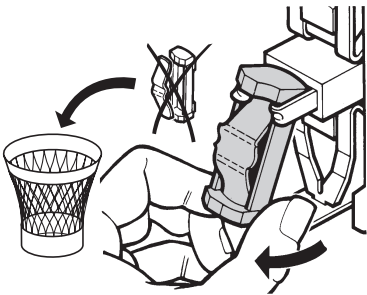
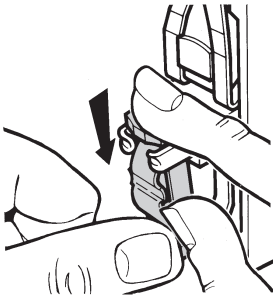
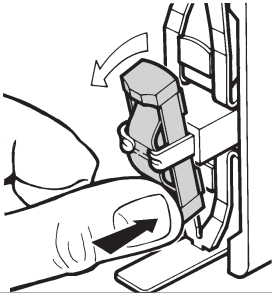

Montage / Assembly / Montage / Montaggio / Montaje / Сборка  
**LC1-F115 ... F265** **LC1-F330 ... F800**

(LA5-FF/FG/FH)

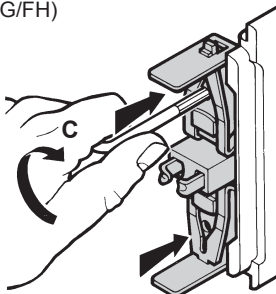

	F115	F150	F185	F225	F265
<b>c : N.m</b>	3,6	3,6	6,6	6,6	6,6
<b>lb.in.</b>	32	32	58	58	58

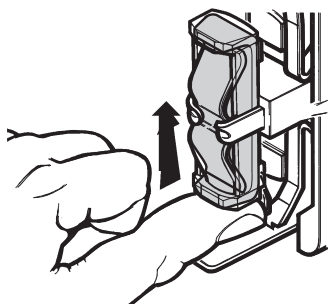

(LA5-F.)

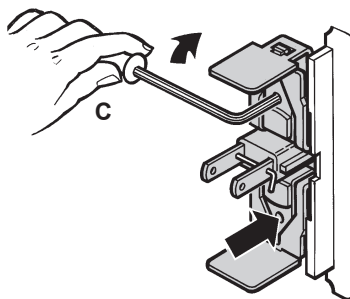

	F330	F400	F500	F630	F780	F800
<b>c : N.m</b>	10	10	18	30	30	30
<b>lb.in.</b>	88	88	160	265	265	265

